



GAS SPRINGS AND DAMPERS

SOLUTIONS FOR
INDUSTRIAL
APPLICATIONS

LIFT-O-MAT[®]

BLOC-O-LIFT[®]

STAB-O-SHOC[®]

STAB-O-MAT[®]



STABILUS – A COMPANY WITH A TRADITION IN INNOVATIONS

PIONEER PERFORMANCE

Stabilus has more than 80 years experiences in the manufacture of hydropneumatics equipment. In addition to having produced hydraulic dampers over several decades, Stabilus presented the world's first standard production gas spring in 1962. To date, it has produced over 2 billion gas springs. With its gas springs and hydraulic dampers, Stabilus is the world market leader with an annual production of more than 140 million units.

GLOBALLY ACTIVE

With a global sales and service network and 11 production sites in nine countries Stabilus supplies and supports more than 2,600 customers worldwide.

FOR ALL BUSINESS SECTORS

Known for more than half a century in the automotive and furniture industries, Stabilus gas springs have now also become an indispensable element in countless applications in the most diverse sectors.

Gas springs and dampers for industrial applications and for applications in automotive engineering. Compact design, high level of operating convenience and safety in use continue to expand the field of applications for Stabilus products.

Industrial applications:

- Furniture
- Medical engineering
- Building industry
- Mechanical engineering

Applications in automotive engineering:

- Automotive superstructures
- Construction machines
- Agricultural vehicles
- Buses
- Railway

CUSTOMER SATISFACTION

Customer service and customer satisfaction are key objectives for the company. Stabilus is known in particular for its technical innovation, quality and competitive pricing in all its business units.

HIGHEST QUALITY

As the leading gas spring supplier worldwide, our quality management system fulfills without question the high quality requirements of international standards, such as DIN EN ISO 9001-2000, as well as the new world standard ISO/TS 16949-2002 with the regulatory requirements of QS 9000, VDA 6.1, EAQF, and AVSQ.

CARE FOR THE ENVIRONMENT

Stabilus places utmost importance in achieving environmentally friendly production methods. Its success in this area is documented by the certification of its environmental management system in conformity with DIN EN ISO 14001 as well as with EC-environmental management systems (EMAS).

SERVICE AND TECHNICAL APPLICATION SUPPORT

Stabilus of course provides extensive technical, design and installation support in specific applications. The extensive know-how of our application consultants and technicians coupled with our highly efficient installation proposal programmes and practical arrangements, also on site, ensure optimal solutions.

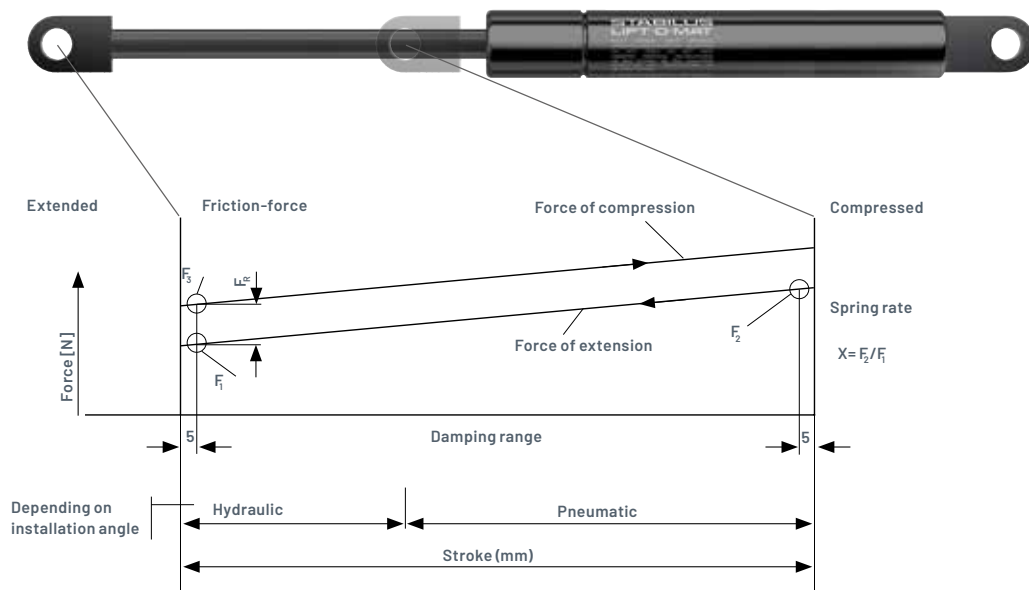

PRODUCT CHARACTERISTICS, ADVANTAGES, USES

OPERATING PRINCIPLE OF A GAS SPRING

The gas spring is a hydropneumatics adjusting element, consisting of a pressure tube, a piston rod with piston and appropriate connection fittings. It is filled with compressed nitrogen, which acts with equal pressure on differently dimensioned crosssectional areas of the piston. This produces a force in the extension direction. This extension force can be exactly defined within physical limits through the appropriate selection of the filling pressure.

SPRING CHARACTERISTIC CURVE AND F_1 FORCE

The spring characteristic curve describes the gas spring progression force over the stroke, i.e. from the extended to the compressed state and vice versa. Unlike mechanical springs, gas springs have an extremely flat, almost linear characteristic curve and therefore allow a uniform comfortable adjustment or pivoting movement.

The spring rate, X , representing the force ratio F_2/F_1 , lies between 1.2 and 1.4 with standard gas springs. Other values can be defined on request and according to the application. Together with the dimensions, the F_1 force is the major descriptive feature for the choice of a gas spring and it is therefore specified in all Stabilus brochures. It defines the value of the spring force and is measured 5 mm before the end of the extension movement. The difference between the force lines for the compression and ex-tension direction, F_R , is the result of friction effects.

EXTENDING SPEED AND DAMPING

A significant advantage of gas springs over mechanical springs is the definable speed curve, which allows for a damped and comfortably adjusting movement. Two types of damping can be distinguished:

■ Hydraulic damping

The extending speed is determined both by the arrangement and the diameter of the bores in the piston and by the viscosity of the oil used. When the gas spring is installed with the piston rod facing down the extending piston first travels through the gas-filled and then through the oil-filled part of the pressure tube. As soon as it is immersed in the oil the piston rod moves at a considerably lower speed.

■ Dynamic damping

Here the bore in the piston is replaced with a longitudinal groove in the wall of the pressure tube which serves as a bypass. Its geometry and the length determine the damping curve. This technique allows position-independent damping of the gas springs.

CHOICE AND APPLICATION OF GAS SPRINGS

DIMENSIONS ACCORDING TO CHOICE

Stabilus offers an extremely wide range of gas spring types, which vary in respect of their external dimensions, speed curves and extension variants, and invariably meet the most stringent requirements. A large selection is included in the Stabilus standard product range and can be delivered at short notice.

SERVICE LIFE AND MAINTENANCE

Gas springs are maintenance-free! They are designed to specific requirements and operate for years and years without failure when properly installed. Also for particularly high numbers of load alterations special sealing systems are available which allow e.g. specific gas springs in swivel chairs to withstand up to one million load cycles without damage.

CONNECTIONS

Different connections are available depending on the application. Stabilus therefore offers a wide range of plastic or metal hinge eyes, including the easy-to-mount angle joint that only has to be fitted on the ball socket and allows for twist-free installation.

INSTALLATION INSTRUCTIONS

■ Twist-free connection

For maximum service life, gas springs should not be exposed to twists or lateral forces. Suitable connection fittings, e.g. angle joints, can be used for the twist-free connection of the gas springs.

■ Installation position

Gas springs – except those designed for position-independent installation – are preferably installed with the piston rod facing down so as to maximise the hydraulic damping effect and to ensure optimal lubrication of the guide and seal system.

■ Temperature behaviour

The temperature of the gaseous nitrogen inside the gas spring influences its extension behaviour within certain limits. The standard temperature range lies between $-30\text{ }^{\circ}\text{C}$ und $+80\text{ }^{\circ}\text{C}$. In addition, gas springs with special sealing systems for extreme loads are available.

■ Operational safety

The operational safety of the gas spring is primarily achieved by seals designed to keep the gas pressure inside. For your protection, no bending loads should be exerted on the gas springs. Damage caused by subsequent mechanical operations, including welding, performed on the gas springs, as well as contamination or painting of the piston rod may lead to the failure of the devices.

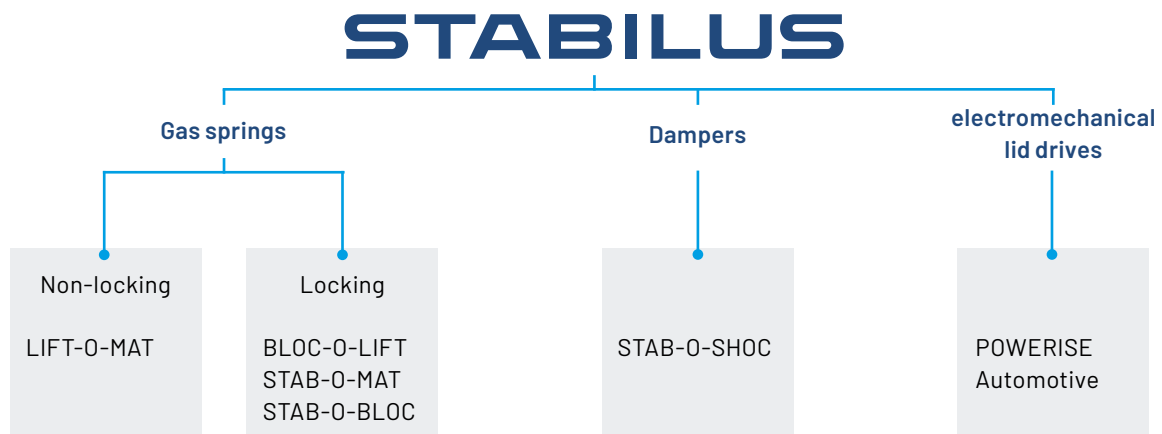

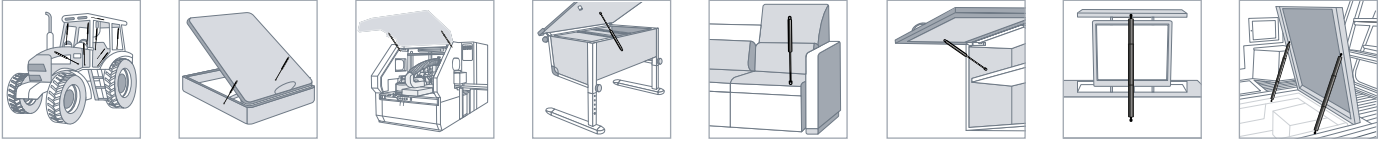

LIFT-O-MAT®

Non-blocking gas springs

LIFTING, LOWERING, MOVING AND ADJUSTING

With their accurately adjusted extension force and application specific damping LIFT-O-MAT gas springs offer optimum weight compensation, force support, they open and close flaps and bonnets and ensure user-friendly movement sequences thanks to their damping characteristics.

PRODUCT VARIANTS

■ LIFT-O-MAT FR – for infinitely variable holding in place

The LIFT-O-MAT FR is a gas spring featuring a special piston package with an integrated friction element, which – in addition to force assist – allows infinitely variable holding over the entire adjustment range. Even weight fluctuations between defined limits, for example due to varying loads, can be offset.

■ HYDRO- LIFT

The HYDRO- LIFT features a valve in its piston, which, in addition to user-optimized force assist, allows infinitely variable positioning. Depending on the design of the HYDRO-LIFT, the hold function can be active across the entire adjustment range or in one or more partial sectors of the application.

■ INTER-STOP with holding range

The INTER-STOP gas spring combines the properties of the LIFT-O-MAT with dynamic damping and the holding force working in the extension direction. The stroke can be divided into two or more function areas. For example, one function area

might perform the stopping or hold the application load in any position, until a manual force is applied, for example by hand.

■ LIFT-O-MAT – with end position locking

In addition to force support, the LIFT-O-MAT gas spring with end position locking also provides a safe mechanical lock for the application in the extended position. Generally, two variations are available: Gas springs with the lock on the outside or gas springs with the lock on the inside.

■ LIFT-O-MAT – with decreasing or progressive spring characteristic curve

LIFT-O-MAT gas springs with additional coil springs will cause very high or very low spring forces in the end positions, depending on installation orientation. Depending on the application or requirement, rubber cushions or coil springs are used to achieve a very gentle end stop, adding to the gas spring effect. The coil spring length and force can be optimized for the application.

Characteristics and benefits:

- Available in a variety of standard sizes and force variants
- Linear spring curve for uniform force progression over the entire spring travel
- Available with progressive or degressive spring curve for force support at stroke start or end position
- Available with dynamic or hydraulic damping according to application and fitting position
- Various connection systems for practical and swift installation

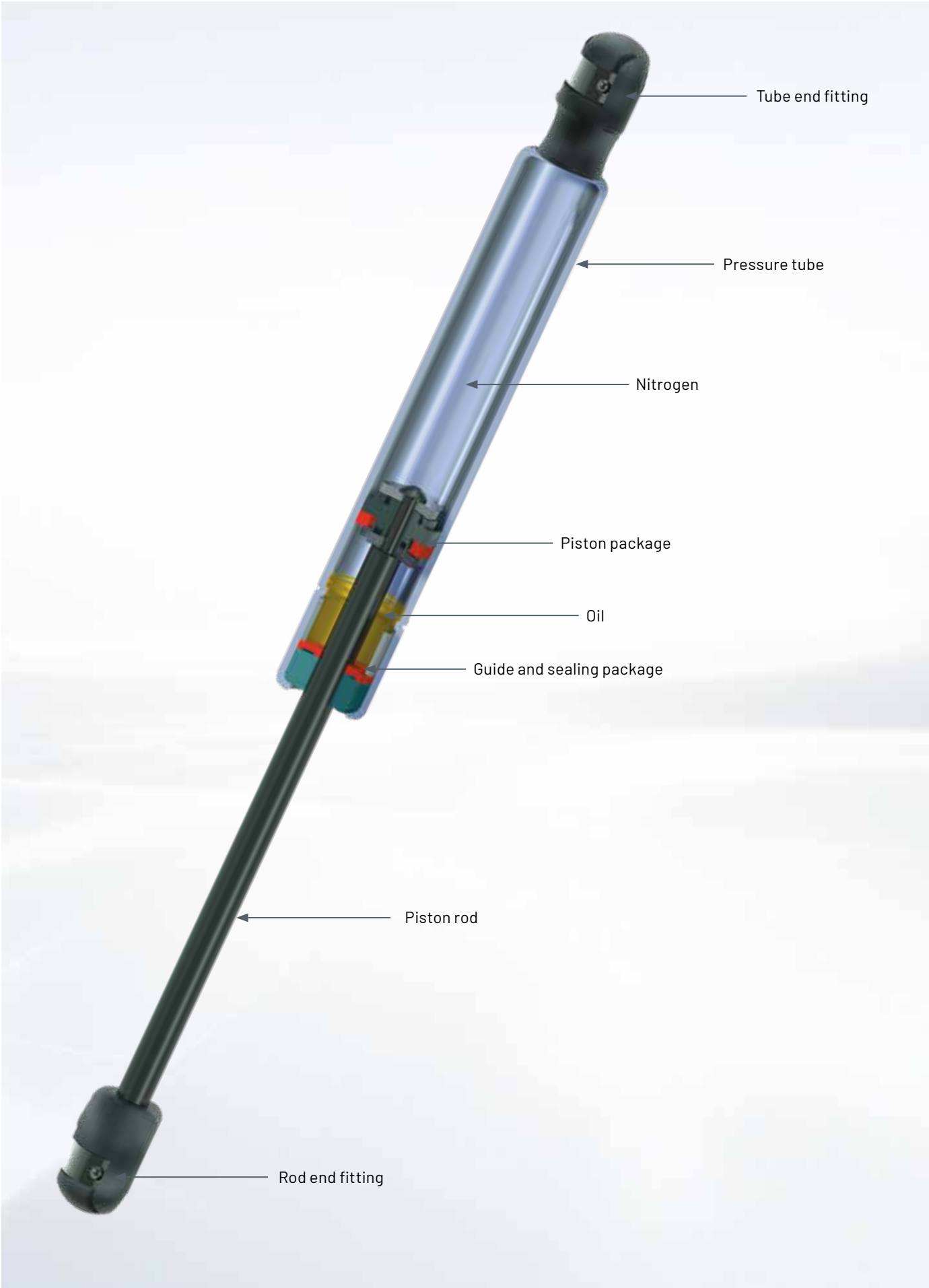

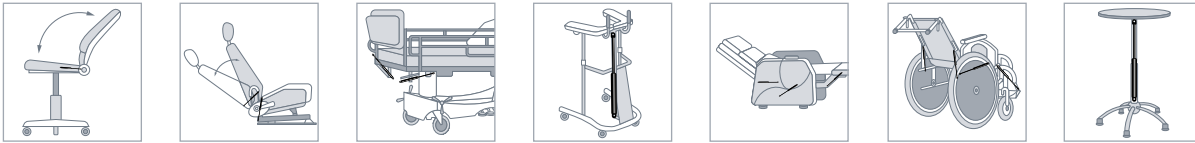

BLOC-O-LIFT®

Locking gas springs

VARIABLE POSITIONING, RIGID OR SPRING BLOCKING

BLOC-O-LIFT gas springs basically work on the same principle as the LIFT-O-MAT gas springs. In addition, BLOC-O-LIFT gas springs can be blocked in any position, with springing or rigid blocking in the extension or compression direction depending on the design. Variable blocking is made possible by integrating the valve into the piston, which separates both pressure chambers gas tight. When the valve is closed, there by interrupting the gas exchange between both pressure chambers, the BLOC-O-LIFT gas spring is blocked. The valve closes automatically when the valve tappet is released externally. The springing blocking variant is ideal for the smooth dampening of e.g. shocks, impacts or pulse-type peak loads.

PRODUCT VARIANTS

■ BLOC-O-LIFT with Override function

A special variation of this BLOC-O-LIFT gas spring comes with an additional override function. This function, designed for special customer requests, is to protect the application from overload. The override function is available in the tension or compression direction.

■ BLOC-O-LIFT OBT – locking in the compression direction

BLOC-O-LIFT OBT allows for convenient upward motion of applications, such as table tops, without the need to actuate a release. It is variably locking in the compression direction.

■ KOMBI-LIFT for special applications

The KOMBI-LIFT is a combination of a locking and non-locking gas spring; a specified segment of the stroke can lock during extension. The functional ranges can be arranged in any location of the stroke. It is compressed independently of the lever position, like a standard LIFT-O-MAT.

■ HYDRO-BLOC

The HYDRO-BLOC is a locking element without extension force, with rigid locking in both directions. It is designed for applications requiring tuned damping and variable rigid locking which do not need any force support.

■ BLOC-O-LIFT T with specially flat spring characteristic

The BLOC-O-LIFT T gas spring, designed specifically for height adjustable tables, has a very flat spring characteristic curve, providing even adjustment over the entire stroke. This makes it easy to adjust the table top height, regardless of its weight, without the table losing stability or strength.

Characteristics and benefits:

- Numerous sizes and force variants are available as standard products
- Linear spring characteristics for evenly low force increase across the entire range of movement
- Progressive or decreasing spring characteristics for force supply at the beginning or end of the stroke
- Up on request, available with hydraulic damping, for example, for targeted slowdown shortly before the end stop
- Rigid or spring blocking in the extension or compression direction. Optionally, a position independent variant is available
- Also available with a small actuation range of 1 mm (standard 2.5 mm) for very easy operation
- Up on request, also suited for continuous actuation

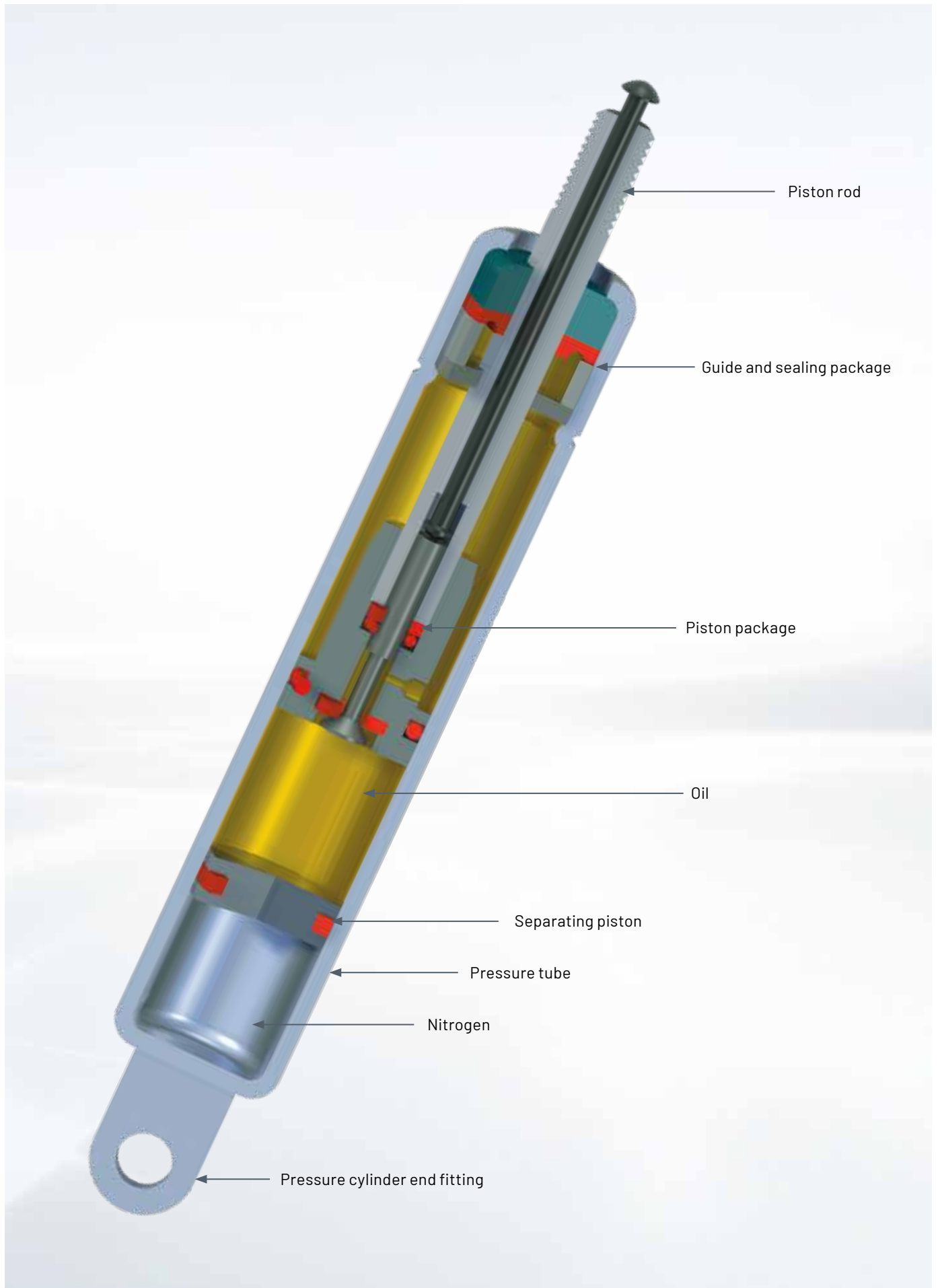

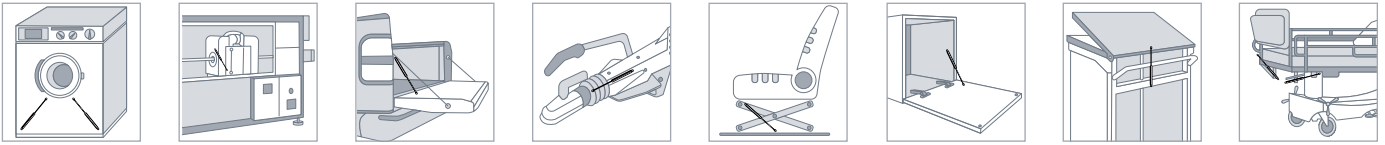

STAB-O-SHOC®

Oil-hydraulic dampers

HYDRAULIC DAMPENING OF VIBRATIONS AND MOTIONS

Stabilus offers dampers for a variety of applications. Whether in automotive manufacturing, process technology manufacturing, industrial applications, or in the furniture industry – STAB-O-SHOC dampers from Stabilus are always there when it comes to positively affecting motion and vibrations.

The vibration system transmits motion into the dampers and converts the kinetic energy into thermal energy. Consequently, the damping forces generated will always depend on the piston speed. Hydraulic dampers with a modular piston system allow adapting the tensile and compression forces, which may differ to the application.

CHARACTERISTICS

- Not orientation-specific: Can be installed in any position.
- Orientation-specific: Install with piston rod down or up.
- Friction fit: When the load is reversed, the damping force will be actuated immediately. The force is transmitted without a no-load stroke.
- No friction fit: When the load is reversed, damping force and force transmission will be actuated with a delay.
- Extension force: Static extension force for the piston rod can be specified.

PRODUKTVARIANTEN

- For position dependent or position independent installation
- Vibration dampening only at specific frequencies (frequency dependent dampening) upon request
- Dampers are designed to optimally match the particular application
- Dampers with or without extension force
- With damping forces in one direction or in the extension and compression direction

Characteristics and benefits:

- Compact dimensions with maximum reliability and durability
- Electrically adjustable dampers Suited for operating temperatures between -40 °C and +130 °C
- Defined linear, progressive or degressive damping force characteristic for optimal results
- Variable damping rate e.g. for steering dampers and driver seat dampers
- Frequency dependent dampening
- Several connection variants for easy installation

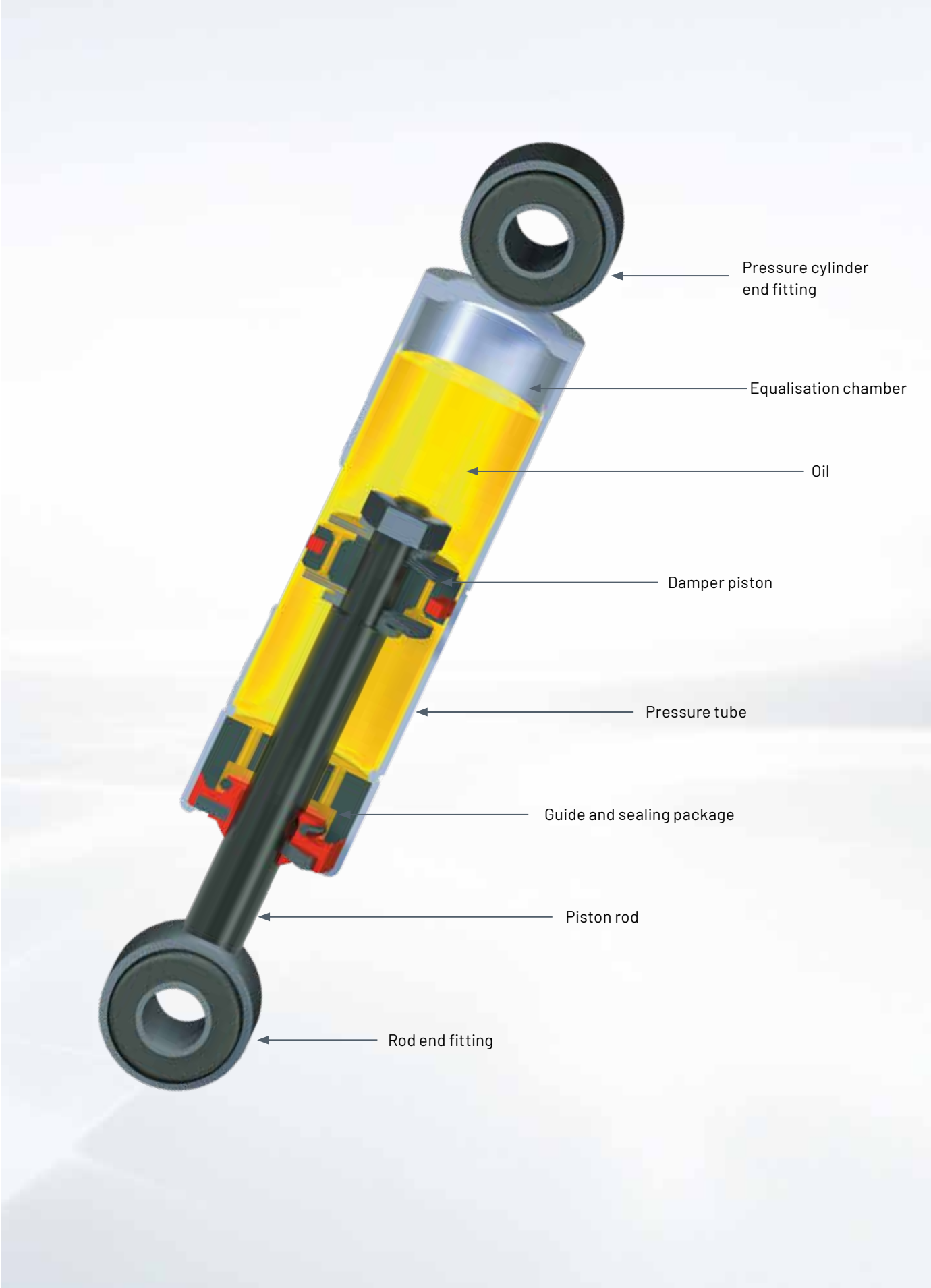



STAB-O-MAT®

Elastic locking gas springs

FOR VARIABLE SEAT HEIGHT ADJUSTMENT

STAB-O-MAT and STAB-O-BLOC gas springs are lock able gas spring specifically for variable and comfortable adjustment of the seat height in office swivel chairs, task chairs, executive chairs, stools, etc.

PRODUCT CHARACTERISTICS

The difference between the two locking gas springs STAB-O-MAT and STAB-O-BLOC lies in their structure. While the STAB-O-MAT absorbs the weight on the seat and bending moments (caused by uneven weight distribution on the seat) with the properly designed pressure cylinder, these tasks are performed by the internal gas spring and the additional support tube in the STAB-O-BLOC. Of course, both types of gas springs comply with the respective standards. They are both available with the same forces and in the same dimensions, which makes them interchangeable. Interna rubber cushions form the

bottom end stop. Where necessary, special deep cushioning systems offer additional comfort. Depending on the individual requirements, STAB-O-MAT and STAB-O-BLOC gas springs are available as complete columns or individual gas springs.

Special Product Versions for Demanding Swivel Chairs

- Special Seating Comfort due to deep cushioning systems
- Multi-functional column
- Better Height Adjustment with the Telescopic Stand Tube Column
- Swivel resistant column
- Column with Stop Function

Characteristics and benefits:

- Available in various lengths and with strokes of 50 to 300 mm
- As complete columns with various diameters of upright tube and taper dimensions for mounting into the seat carrier or in the swivel chair base
- As telescopic column with over-proportional adjustment range
- With anti-torsion device, e.g. for added operational safety
- With various surface finishes of upright tube, e.g. enamelled or chromium-plated
- With additional mechanical deep springing systems for added comfort, also in lowest seat position
- With adjustable release pins and short release travels and also with reduced release force

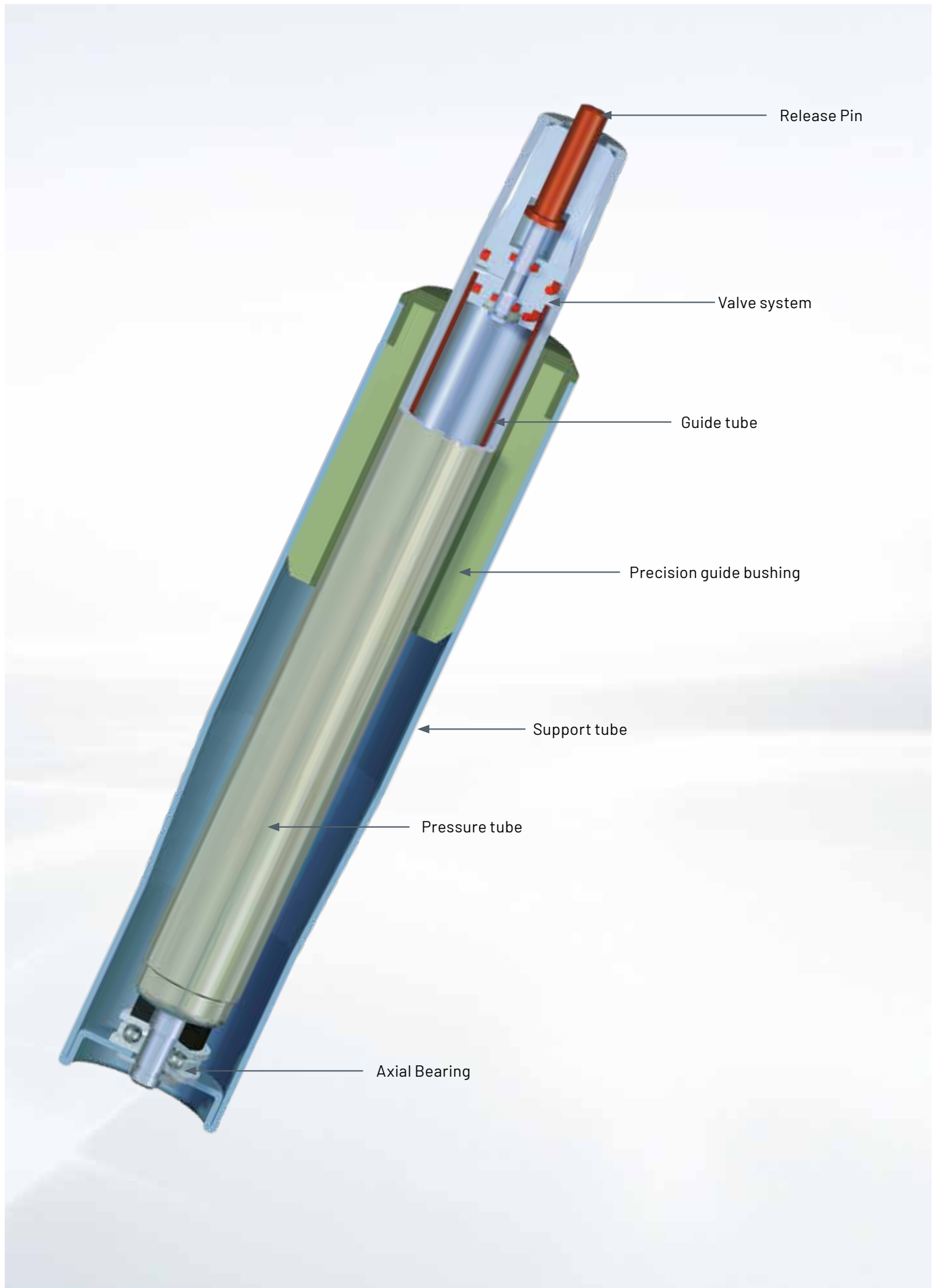

NOTES ON GAS SPRING DESIGN AND INSTALLATION CALCULATION

The Stabilus installation program allows us to design your optimized gas spring and its connection for each special application case.

For this, we will need the following data for the application, e.g., a flap:

- Dimensions, location of the center of gravity and weight
- Opening angle to be accomplished
- Installation space available for the gas spring
- Point at which manual force is applied (handle)
- Temperature range
- Connection technology

This data will yield:

- Stroke A [mm]
- Extended length B [mm]
- Extension force F_1 [N]
- Manual force curve F_H [N] / α [degrees]

STROKE AND EXTENSION FORCE OF A GAS SPRING TO OPEN A FLAP

min. stroke	A = B - E	Extension force	$F_1 = \frac{F_g \times L_g}{n \times L_1} \times R$
-------------	------------------	-----------------	--

- A:** Stroke of the gas spring [mm]
- B:** Extended length of the gas spring [mm]
- E:** Compressed length of the gas spring [mm]
- F₁:** Extension force of the gas spring [N]
- F_g:** Weight force of the application in the centre of gravity [N]
- g:** Acceleration due to gravity 9,81[m/s²]
- L₁:** Vertical distance bearing/deformation axis F₁ [mm]
- L_g:** Vertical distance bearing/deformation axis F_g [mm]
- R_g:** Radius bearing/centre of gravity [mm]
- m:** Mass (weight) of the application [kg]
- n:** Number of gas springs [/]
- R:** Reserve force factor 1,2 ... 1,3 [/]

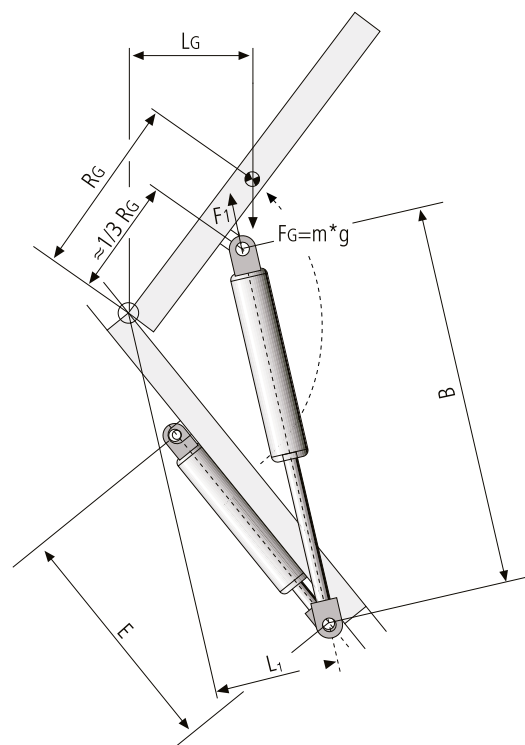

YOUR MOTION. OUR SOLUTION.

STABILUS

THE GLOBAL MOTION CONTROL SOLUTION PROVIDER TO THE INDUSTRY

- Specialized industrial brands with unique solutions and expertise for each market.
- Wide product range – from simple to complex requirements across all industries.
- Broad global presence that closely connects us with all markets.



Stabilus group of industrial brands

STABILUS

Globally leading series gas spring manufacturer meeting highest automotive quality standards for industrial products in all plants.



FABREEKA
A STABILUS COMPANY

Leading supplier for individual vibration isolation and shock control solutions.



ACE
A STABILUS COMPANY

Expert in industrial damping and deceleration with excellent customer support satisfying most demanding application requirements.



HAHN
GASFEDERN
A STABILUS COMPANY

Experienced provider of customized and special gas springs with very fast time to market.



General Aerospace
A STABILUS COMPANY

Innovative supplier of distinctive airline motion control solutions.



TECH PRODUCTS
A STABILUS COMPANY

Experienced manufacturer of elastomeric vibration isolators and shock mounts.



Stabilus GmbH

Wallersheimer Weg 100

56070 Koblenz

Germany

T +49 261 - 8900-0

info@stabilus.com

www.stabilus.com

QR code takes you to our
International Locations.



@Stabilus



@stabilusgroup